



CSD單片式排煙口

Application and design 應用與設計

The CSD Ceiling Smoke Dampers work well with smoke management systems. The Maximum Velocity Rating is 2000 ft/min (10.2 m/s), the Pressure Rating is 4 in-Wg (1kPa), and the air leakage is Class I. It may be used for the dividing wall (the brick wall or the gypsum board) and the floor with the mounting.

CSD 單片式排煙口適合用於消防煙控系統。

CSD 適用的最大環境風速為 2000 FPM

(10.2m/s)，最大風壓 4inWg (1kPa)，洩漏等級 class I，可安裝在分間牆區劃隔間，亦可安裝於樓地板間之運用



Standard construction 標準結構

Frame: Material - galvanized steel
Thickness - 1.6mm
Depth - 200mm

Blades: thickness 1.6mm galvanized steel.
Jackshaft: Ø 10mm diameter plated steel.

框架：材質 - 高品質鍍鋅鋼板
板厚 - 1.6mm
深度 - 200mm

葉片：1.6mm 厚之高品質鍍鋅鋼板製作。

軸心：使用 Ø10mm 鍍鋅圓軸。

塗裝：依指定顏色

Damper Sizes 風門尺寸

Minimum Size : 12"×12"(305×305mm)

Maximum Size : 36"×36"(914×914mm)

最小尺寸：12"×12"(305×305mm)

最大尺寸：36" × 36"(914×914mm)

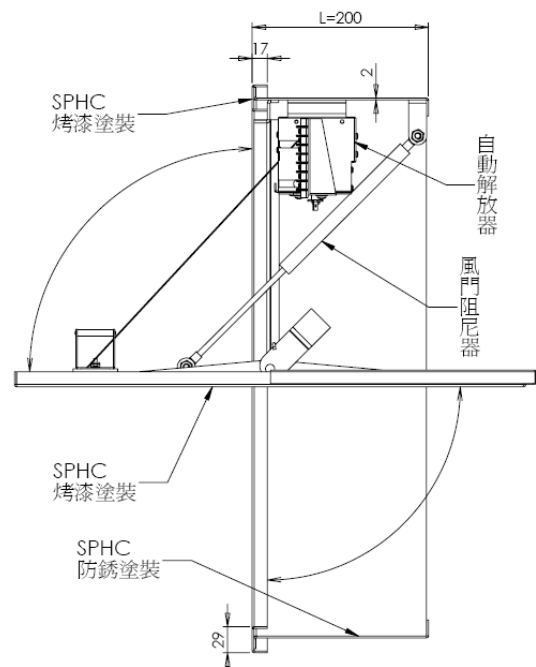
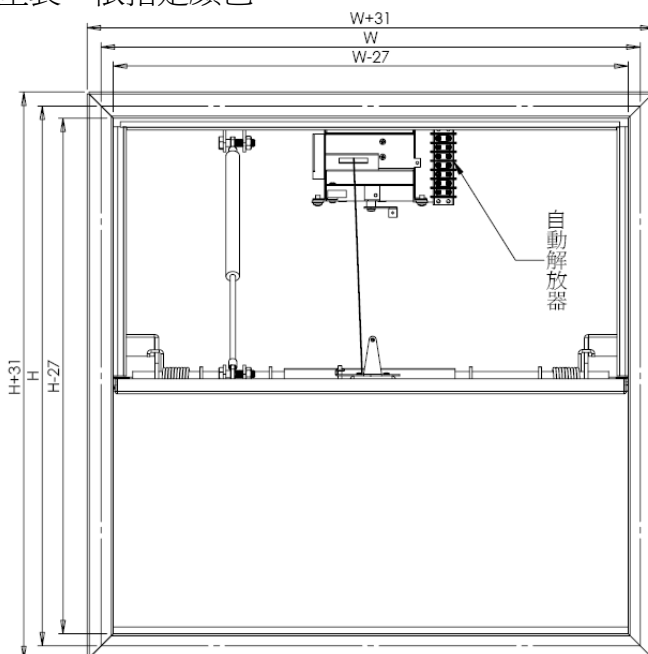



CSD單片式排煙口

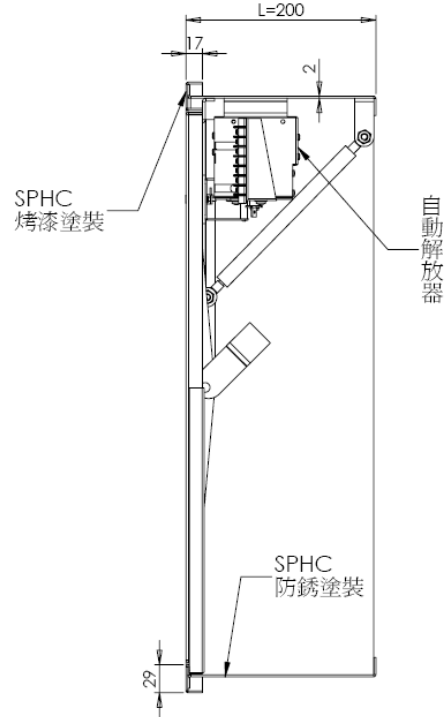
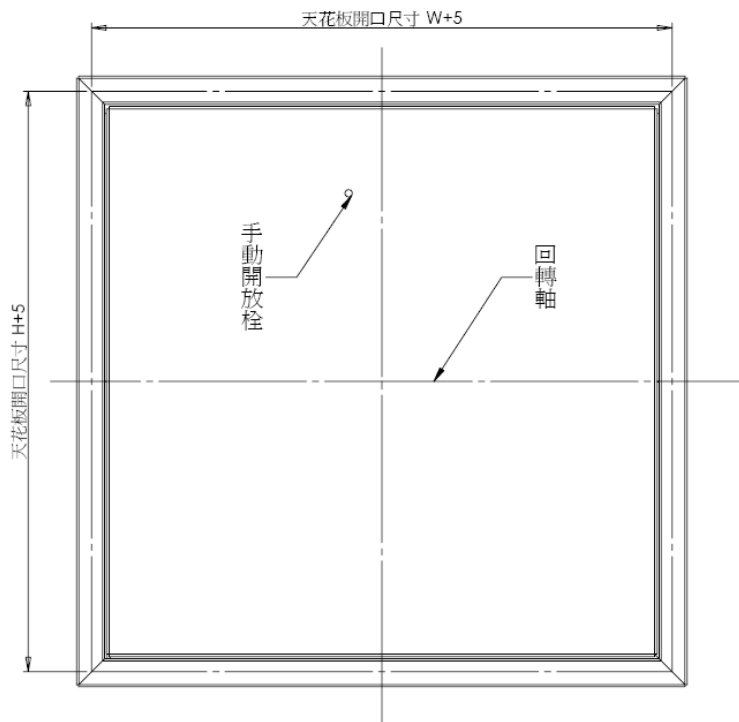

Turned on

operation : Electrically or manually

Voltage : DC24V±10% 60Hz

Rating : 0.4A 以下

Runtime : 3sec

Return

operation : Electric

Voltage : DC24V±10% 60Hz

Rating : 0.3±0.1A

Runtime : 35sec

開啓時

操作方法：電動開啓，手動開啓

電壓：DC24V±15% 60Hz

電流：0.4A 以下

作動時間：3 秒

復歸時

操作方法：電動關閉

電壓：DC24V±15% 60Hz

電流：0.3±0.1A

作動時間：約 20 秒

